

材質・表面処理

| 材質 | 表面処理 | Code |
|--|-----------------|------|
| S45C | 処理無 | SC |
| | 四三酸化鉄被膜 | SCB |
| | パーカー | SCP |
| | 無電解ニッケルメッキ | SCM |
| | 窒化 (表面: 450~HV) | SCN |
| S45C 高周波焼入 (40HRC~) (深度0.8-2mm) | 処理無 | SH |
| | 四三酸化鉄被膜 | SHB |
| | パーカー | SHP |
| | 無電解ニッケルメッキ | SHM |
| A5052 | 処理無 | AM |
| | アルマイト (白色) | AMW |
| | アルマイト (黒色) | AMB |
| SUS304 | 処理無 | SU |

穴種選択表

共通加工条件に注意 P.1037~1042

| 穴種 | タップ穴 | 通し穴 | ザグリ穴 | | | | | | | | | | | | | | | | | | | | | | | | | | | | |
|------|---|-----|------|-----|--------|----|--|--|--|--|--|---|---|---|---|---|----|-----|-----|-----|-----|-----|---|----|----|-----|---|-----|----|----|----|
| Code | M | N | Z | | | | | | | | | | | | | | | | | | | | | | | | | | | | |
| 形状図 | | | | | | | | | | | | | | | | | | | | | | | | | | | | | | | |
| 加工仕様 | <table border="1"> <thead> <tr> <th>寸法</th> <th colspan="6">ボルト呼び径</th> </tr> <tr> <th></th> <th>3</th> <th>4</th> <th>5</th> <th>6</th> <th>8</th> <th>10</th> </tr> </thead> <tbody> <tr> <td>d+h</td> <td>3.5</td> <td>4.5</td> <td>5.5</td> <td>6.5</td> <td>9</td> <td>11</td> </tr> <tr> <td>d1</td> <td>6.5</td> <td>8</td> <td>9.5</td> <td>11</td> <td>14</td> <td>18</td> </tr> </tbody> </table> | | | 寸法 | ボルト呼び径 | | | | | | | 3 | 4 | 5 | 6 | 8 | 10 | d+h | 3.5 | 4.5 | 5.5 | 6.5 | 9 | 11 | d1 | 6.5 | 8 | 9.5 | 11 | 14 | 18 |
| 寸法 | ボルト呼び径 | | | | | | | | | | | | | | | | | | | | | | | | | | | | | | |
| | 3 | 4 | 5 | 6 | 8 | 10 | | | | | | | | | | | | | | | | | | | | | | | | | |
| d+h | 3.5 | 4.5 | 5.5 | 6.5 | 9 | 11 | | | | | | | | | | | | | | | | | | | | | | | | | |
| d1 | 6.5 | 8 | 9.5 | 11 | 14 | 18 | | | | | | | | | | | | | | | | | | | | | | | | | |

| 形状No. | 材質・表面処理 Code | 指定1mm単位 | | | | | | | | | | 0.1mm単位 | | 穴種選択 | |
|-------|-----------------|---------|----|----|---|---|---|---|----|---|---|---------|------|------|--|
| | | A | B | T | H | F | W | K | L | P | J | G | Code | 呼び径 | |
| SLBA | SC SH AM | | | | | | | | | 4 | J | | Z | 3 | |
| SLBB | SCB SHB AMW | 30 | 20 | 10 | H | F | | | 30 | J | | N | 4 | | |
| SLBC | SCP SHP AMB | | | | | | W | K | L | | | G | N | 5 | |
| SLBD | SCM SHM SU | 200 | 80 | 70 | | | | | | | | G | N | 6 | |
| | | | | | H | F | | | | | | G | M | 8 | |
| | | | | | | | | | | | | | | 10 | |

加工条件 H≥T/5 T/3(H/3)≤W≤B-10 P≥T/3
F≤HX5 K≤WX2

1. 指示なき面取りはC0.2~0.5
2. DH7公差、直角度はスリット加工前の公差です。
3. 高周波焼入は//部のみ適用
4. スリット部詳細寸法

| P穴 | S |
|-------|-----|
| 3~6 | 1.0 |
| 7~12 | 1.5 |
| 13~29 | |
| 30 | 2 |



形状No. - 材質Code - A - B - T - H - F - W - K - L - P - J - G - 穴種選択Code・呼び - オプション



注文例 SLBD - SCP - A88 - B36 - T24 - H18 - F41 - W16 - K18 - L60 - G22 - N6



5・8 日日出荷 ストックB・C

| Code | SC | SCB | SCP | SCM | SCN | SH | SHB | SHP | SHM | AM | AMW | AMB | SU |
|------|----|-----|-----|-----|-----|----|-----|-----|-----|----|-----|-----|----|
| 出荷日 | 5 | 8 | 8 | 8 | 8 | 8 | 8 | 8 | 8 | 5 | 8 | 8 | 5 |
| ストーク | B | C | C | C | C | X | X | X | X | B | X | X | X |

※ ストック料金: 1,000円/1本 (同一サイズ3本以上は一律2,700円)

オプション

| オプション | T・H寸法公差変更 | ヘリサート追加 |
|----------|--|--|
| Code | TKC | HSC |
| オプション規格 | <ul style="list-style-type: none"> SLBA・SLBC=T寸法 SLBB・SLBD=H寸法 | <ul style="list-style-type: none"> T≥M SLBC・SLBDのA5052でタップ穴を指定したときのみ適用 |
| 指定方法 | TKCを型式末尾に追加 (例) ~TKC | HSCを型式末尾に追加 (例) ~HSC |
| @/1 Code | 1,000 | 400 |



数量スライド価格 (1円未満切り捨て)

| 数量 | 1 | 2~4 | 5~10 | 11以上 |
|-----|---|-----|------|-------|
| 値引率 | | 10% | 15% | ※お見積り |

※出荷日・価格共にお見積り

形状価格は表面処理「処理無」の価格です。表面処理を指定した場合は、形状価格に表面処理価格を加算してください。

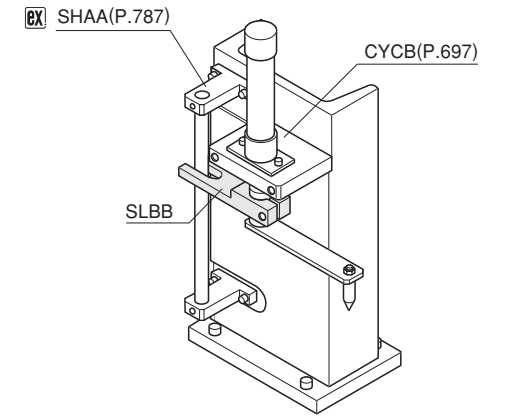

(価格算出例)
SLBA-SC-A80-B50-T10-***を2個発注の単価
形状価格 × 数量スライド = 単価
3,700 × 0.9 = 3,330 (円)

| A | B | T | 形状価格 @単価 U/Price | | | | | | | | | | | | 表面処理価格 @単価 U/Price | | | | | | | | | |
|---------|-------|-------|------------------|-----------|--------|--------|--------|-----------|--------|--------|-------|-----------|--------|--------|--------------------|-----------|--------|--------|----------------|-------|------------|-------|---------|---------|
| | | | SLBA | | | | SLBB | | | | SLBC | | | | SLBD | | | | S45C・S45C高周波焼入 | | S45C | A5052 | | |
| | | | S45C | S45C高周波焼入 | A5052 | SUS304 | S45C | S45C高周波焼入 | A5052 | SUS304 | S45C | S45C高周波焼入 | A5052 | SUS304 | S45C | S45C高周波焼入 | A5052 | SUS304 | 四三酸化鉄被膜 | パーカー | 無電解ニッケルメッキ | 窒化 | アルマイト白色 | アルマイト黒色 |
| 30~80 | 20~50 | 10~30 | 3,700 | 4,070 | 3,340 | 6,280 | 3,820 | 4,200 | 3,430 | 6,440 | 2,990 | 3,290 | 3,030 | 5,560 | 3,140 | 3,450 | 3,140 | 5,760 | 150 | 150 | 180 | 740 | 240 | 310 |
| | | 31~50 | 4,450 | 4,900 | 4,180 | 8,120 | 4,620 | 5,080 | 4,330 | 8,370 | 3,550 | 3,900 | 3,840 | 7,330 | 3,760 | 4,140 | 4,010 | 7,640 | 180 | 220 | 290 | 880 | 400 | 500 |
| | | 51~70 | 5,200 | 5,720 | 5,070 | 9,960 | 5,430 | 5,970 | 5,260 | 10,280 | 4,100 | 4,510 | 4,660 | 9,090 | 4,390 | 4,830 | 4,900 | 9,490 | 260 | 310 | 420 | 1,270 | 570 | 730 |
| | 51~80 | 10~30 | 4,800 | 5,280 | 4,390 | 8,090 | 4,970 | 5,470 | 4,540 | 8,770 | 3,690 | 4,060 | 3,880 | 7,440 | 3,900 | 4,290 | 4,050 | 7,740 | 180 | 220 | 290 | 880 | 400 | 500 |
| | | 31~50 | 5,670 | 6,240 | 5,560 | 11,020 | 5,900 | 6,490 | 5,750 | 11,330 | 4,410 | 4,850 | 5,080 | 10,010 | 4,700 | 5,180 | 5,310 | 10,400 | 300 | 360 | 480 | 1,470 | 660 | 840 |
| | | 51~70 | 6,540 | 7,190 | 6,720 | 13,520 | 6,800 | 7,480 | 6,930 | 13,880 | 5,110 | 5,630 | 6,260 | 12,610 | 5,440 | 5,990 | 6,510 | 13,060 | 410 | 490 | 660 | 2,010 | 900 | 1,150 |
| 81~140 | 20~50 | 10~30 | 5,630 | 6,190 | 4,840 | 9,400 | 5,860 | 6,450 | 5,030 | 9,720 | 4,060 | 4,480 | 3,980 | 7,600 | 4,350 | 4,790 | 4,210 | 7,990 | 180 | 220 | 290 | 880 | 400 | 500 |
| | | 31~50 | 6,470 | 7,120 | 5,890 | 11,660 | 6,750 | 7,430 | 6,120 | 12,070 | 4,740 | 5,210 | 5,030 | 9,890 | 5,100 | 5,610 | 5,310 | 10,390 | 310 | 370 | 500 | 1,520 | 680 | 870 |
| | | 51~70 | 7,290 | 8,020 | 6,940 | 13,940 | 7,630 | 8,390 | 7,210 | 14,430 | 5,390 | 5,930 | 6,060 | 11,820 | 5,810 | 6,400 | 6,410 | 12,810 | 430 | 520 | 690 | 2,110 | 950 | 1,200 |
| | 51~80 | 10~30 | 6,780 | 7,460 | 6,080 | 12,020 | 7,070 | 7,780 | 6,310 | 12,430 | 4,840 | 5,330 | 5,060 | 9,940 | 5,200 | 5,730 | 5,350 | 10,440 | 300 | 360 | 480 | 1,470 | 660 | 840 |
| | | 31~50 | 7,780 | 8,560 | 7,530 | 15,190 | 8,120 | 8,930 | 7,800 | 15,680 | 5,700 | 6,280 | 6,600 | 13,380 | 6,140 | 6,750 | 6,950 | 13,990 | 490 | 590 | 780 | 2,400 | 1,080 | 1,370 |
| | | 51~70 | 8,780 | 9,660 | 9,000 | 18,360 | 9,190 | 10,110 | 9,320 | 18,920 | 6,590 | 7,250 | 8,180 | 16,800 | 7,090 | 7,800 | 8,560 | 17,500 | 690 | 830 | 1,100 | 3,380 | 1,520 | 1,930 |
| 141~200 | 20~50 | 10~30 | 7,320 | 8,050 | 6,290 | 12,220 | 7,620 | 8,390 | 6,540 | 12,640 | 5,280 | 5,820 | 5,170 | 9,880 | 5,660 | 6,230 | 5,470 | 10,390 | 230 | 290 | 380 | 1,140 | 520 | 650 |
| | | 31~50 | 8,410 | 9,260 | 7,660 | 15,160 | 8,780 | 9,780 | 7,960 | 15,690 | 6,160 | 6,770 | 6,540 | 12,860 | 6,630 | 7,290 | 6,900 | 13,510 | 400 | 480 | 650 | 1,980 | 880 | 1,130 |
| | | 51~70 | 9,480 | 10,430 | 9,020 | 18,120 | 9,920 | 10,910 | 9,370 | 18,760 | 7,010 | 7,710 | 7,880 | 15,370 | 7,550 | 8,320 | 8,330 | 16,650 | 560 | 680 | 900 | 2,740 | 1,240 | 1,560 |
| | 51~80 | 10~30 | 8,810 | 9,700 | 9,700 | 15,630 | 9,190 | 10,110 | 8,200 | 16,160 | 6,290 | 6,930 | 6,580 | 12,920 | 6,760 | 7,450 | 6,960 | 13,570 | 390 | 470 | 620 | 1,910 | 860 | 1,090 |
| | | 31~50 | 10,110 | 11,130 | 9,790 | 19,750 | 10,560 | 11,610 | 10,140 | 20,380 | 7,410 | 8,160 | 8,580 | 17,390 | 7,980 | 8,780 | 8,040 | 18,190 | 640 | 770 | 1,010 | 3,120 | 1,400 | 1,780 |
| | | 51~70 | 11,410 | 12,560 | 11,700 | 23,870 | 11,950 | 13,140 | 12,120 | 24,600 | 8,570 | 9,430 | 10,630 | 21,840 | 9,220 | 10,140 | 11,130 | 22,750 | 900 | 1,080 | 1,430 | 4,390 | 1,980 | 2,510 |